

LEX230 Order Form

Date _____
 AVFI Sales REP _____
 Customer Signature _____

Quote No. _____
 Customer No. _____
 AVFI No. _____

Office Use Only

To generate your order form, please refer to the information provided below to insert the alphabetic and/or numeric code in the respective category boxes. Please note that without this filled out Order Form, your purchase **cannot** be processed.

1	2	3	4
Product Model	Finish	Chargeable Accessories (One Code Per Box)	Custom Cutouts
LEX230			

1 Choose Model Style (Front Panel)



Code **LEX230**

3 Chargeable Accessories (Check all that apply)

- Code **00** No Accessories _____ Qty _____
- * Code **D1** **MIC-18** MX418 S/C Microphone _____ Qty _____
- * Code **D2** **LIGHT-18** Gooseneck Light _____ Qty _____
- * Code **D3** **FM3** Timer/Clock _____ Qty _____
- Code **D4** **FAN** Quiet Cooling Fan _____ Qty _____
- Code **E1** **PB** 6 Outlet Power Bar _____ Qty _____
- * Code **E3** **CUB3** Round Cable Well _____ Qty _____
- * Code **E5** **CUB5** Black Round Cable Well _____ Qty _____
- * Code **E6** **CUB5** Silver Round Cable Well _____ Qty _____
- * Code **E7** **PC-PATCH** Power-Data Module _____ Qty _____
- * Code **E8** **CUB8** Tabletop Cable Well _____ Qty _____
- * Code **EA** **CUB4S** Silver Power Panel _____ Qty _____
- * Code **EB** **CUB4B** Black Power Panel _____ Qty _____
- * Code **EF** **CHGQIB** Wireless Charging Station, Black _____ Qty _____
- * Code **EJ** **CUB22** 3 Module Power Panel (Black) _____ Qty _____
- * Code **EK** **CUBM3** 3 Module Power & Data Panel (Black) _____ Qty _____
- * Code **EL** **CUBM4** 4 Module Power & Data Panel (Black) _____ Qty _____
- Code **J0** **DIR9200-5** 5U Rack Module _____ Qty _____
- Code **J3** **DIR9200-8** 8U Rack Module _____ Qty _____
- Code **J4** **DIR9200-10** 10U Rack Module _____ Qty _____
- Code **K1** **C900S** Single Monitor Arm _____ Qty _____

* Cutout Required (Extra Charges will apply)

2 Choose Product Finish

Standard Finishes (Ships within 1-15 business days)

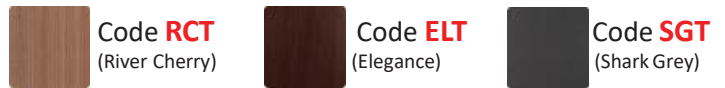

Optional Finishes (Ships within 20 business days)



4 Custom Cutout Option (Extra charges will apply)

Please indicate custom cutout location on the drawing below

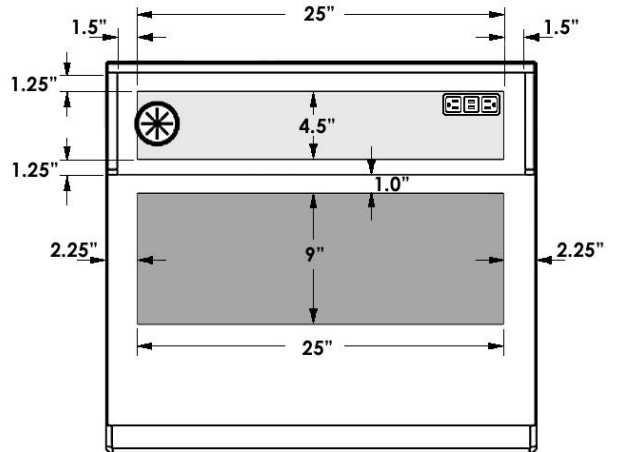

Code **CO** No Custom Cutout

Code **CC** Custom Cutout (Specify on Cutout Area Above)

Top-Rear Panel cutout Area (1x - 25" W x 4.5" D)

Top-Work Surface Panel cutout Area (1x - 25" W x 9" D)

Comments (Please use this section to provide additional information)

Notes

CAD Drawings/Symbols

CAD drawings are available by request at sales@veggroup.net

Custom Cutouts Estimated lead time within 20 business days from receipt of P.O. and signed drawings.

Customizations

Modifications to design such as shape and/or size variations have to be quoted on a per case basis and are applicable for quantities of 10+ only.